

QUANTUM VIBES

A newsletter on
Indian Quantum Technology Activities

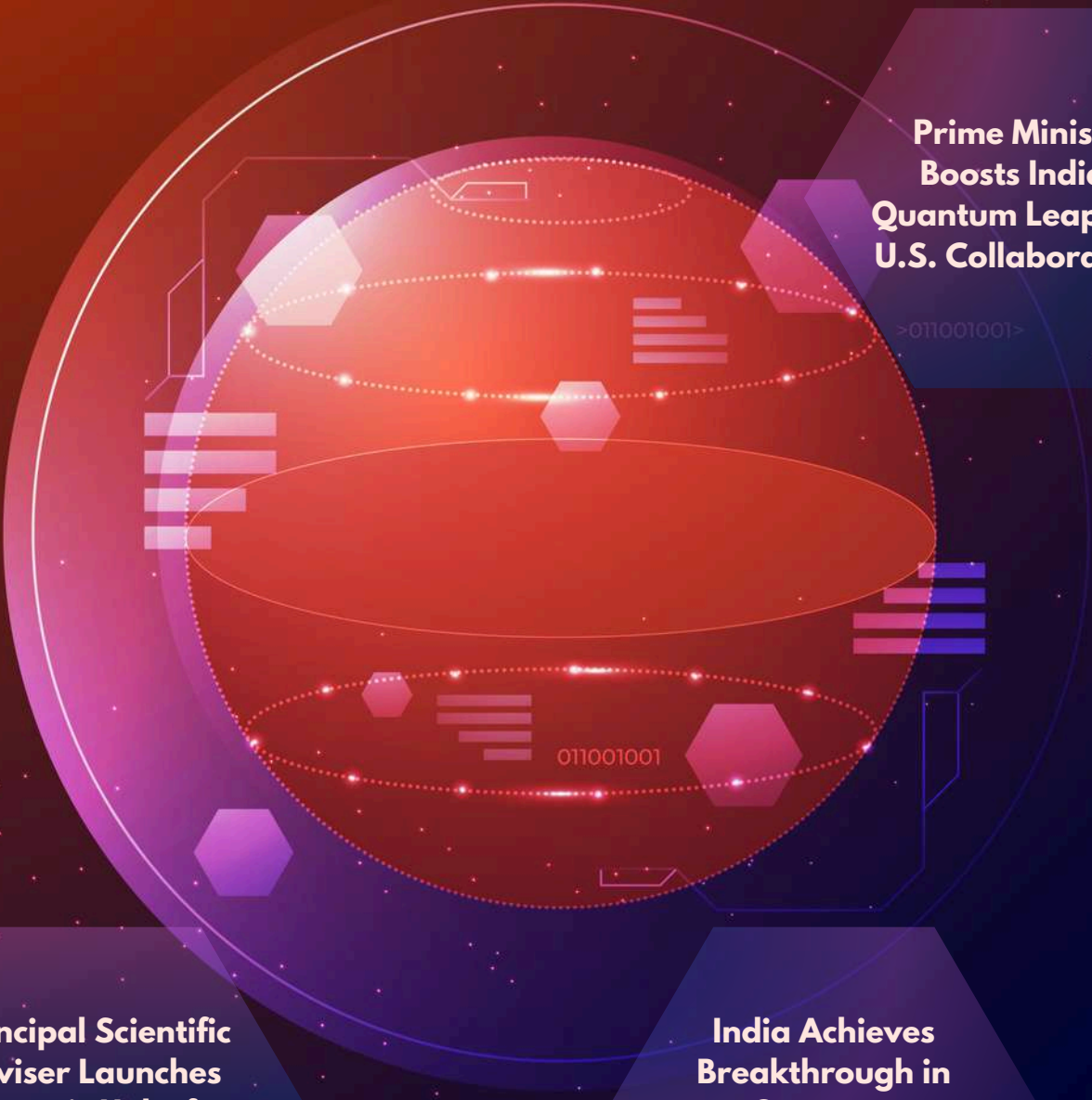

**Prime Minister
Boosts India's
Quantum Leap with
U.S. Collaborations**

>011001001<

**Principal Scientific
Adviser Launches
Thematic Hubs for
National Quantum
Mission**

**India Successfully
Tests 6-Qubit
Quantum Processor**

**India Achieves
Breakthrough in
Quantum
Encryption for
Cybersecurity**

**Q3
2024**

Contents

02



DR. ALOK SHUKLA

05



MR. SUBODH VASHIST



PROF. SADIQ RANGWALA

SECTIONS

01 EXPERT INSIGHTS

Expert insights offer valuable perspectives from leaders and researchers in the field, providing a deeper understanding of complex topics and emerging trends.

08 QUANTUM CURRENTS

Quantum Currents is your go-to source for the latest news and developments in the ever-evolving field of quantum computing and quantum technologies.

18 PUBLICATIONS

Recent high-impact research papers from leading journals. These highlights provide a concise overview of the key findings, methodologies, and implications of the latest studies in quantum technologies.

HIGHLIGHTS

09 PRIME MINISTER'S U.S. VISIT SHOWCASES INDIA'S COLLABORATIVE EFFORTS IN PIONEERING QUANTUM TECHNOLOGY

11 PRINCIPAL SCIENTIFIC ADVISER PROF. A.K. SOOD LAUNCHES THEMATIC HUBS FOR NATIONAL QUANTUM MISSION

12 INDIA DEVELOPS MILESTONE 6-QUBIT QUANTUM PROCESSOR

14 INDIA ACHIEVES BREAKTHROUGH IN RANDOM NUMBER GENERATION FOR CYBERSECURITY



C-DAC Knowledge Park,
No.1, Old Madras Road,
Byappanahalli,
Bangalore - 560038



<https://quantumindia.net>



quantum-outreach-blr@cdac.in

SUBSCRIBE



Editor's Note



Introducing the Q3, 2024 edition of Quantum Vibes, our seventh issue exploring the exciting realm of quantum technologies. In this edition, we highlight cutting-edge research and insights that are driving the future of quantum science, offering a deeper exploration of this intriguing field.

A highlight of this edition, is the spotlight on a Quantum entrepreneurship initiative from Raman Research Institute (RRI) in Bangalore. In their article titled "High-Tech Research to Economy: Quantum Entrepreneurship, the Way Forward," researchers Mr. Subodh Vashist and Prof. Sadiq Rangwala from RRI

Bangalore, founders of the venture nexAtom, delve into the potential of quantum technology in India. They emphasize the importance of self-sufficiency and advocate for a "research to economy" model.

Another article titled "Efficiently Creating Uniform Quantum Superposition States" by Dr. Alok Shukla from Ahmedabad University, discusses the recent breakthroughs in creating superposition states when the number of states is not a power of 2. This new algorithm claims significant reduction in quantum gate complexity, enhancement in resource utilization and also briefs about integrating the UniformSuperpositionGate in IBM and Google's quantum algorithms.

In line with the National Quantum Mission's (NQM) vision to establish India as a global leader in quantum science, this newsletter updates you on innovative projects and collaborations driving the quantum landscape. From advancements in quantum key distribution to quantum sensing, each update reflects the dynamic ecosystem of quantum leap in India. As highlighted during the recent visit of our Hon'ble Prime Minister Shri Narendra Modi Ji to the United States of America, quantum technologies occupy a pivotal position in India's innovation agenda. Notably, India has achieved a significant milestone with the Principal Scientific Adviser to Govt. of India, Prof. A.K. Sood unveiling the thematic hubs and technical groups of the NQM, to accelerate India's quantum initiatives by involving prominent research institutes across the nation. The country has reached yet another significant milestone with the successful testing of a 6-qubit processor and making notable advancements in cybersecurity, highlighted by breakthroughs in generating unpredictable random numbers.

With these exciting advancements, we invite you to immerse yourself in the quantum vibes of innovation, exploration, and collaboration. Together, let's embrace the frontiers of quantum science and harness its potential to redefine the future of technology and communication.

Happy reading!

DR. S.D. SUDARSAN
Editor

MEET THE ADVISORY BOARD



Prof. Abhay Karandikar
Secretary, DST, India



Dr. Praveer Asthana
PSA Fellow



Prof. Apoorva D. Patel
IISc. Bengaluru



Prof. Chandrashekar
IISc. Bengaluru
& IMSc. Chennai



Prof. Amlan Chakrabarti
University of Calcutta



Col. Asheet Kumar Nath
Former Executive Director,
C-DAC Corporate & Strategy

Expert Insights



02 Efficiently Creating Uniform
Quantum Superposition States

05 High-tech Research to Economy
– Quantum Entrepreneurship
the way forward

Efficiently Creating Uniform Quantum Superposition States

Dr. Alok Shukla,
Mathematical and Physical Sciences Division, Ahmedabad University

Uniform Quantum Superposition States

Uniform quantum superposition states are fundamental to quantum computing. In these states, a quantum system is in a superposition where every possible outcome has an equal likelihood of occurring. This implies that each configuration of qubits has the same probability of being observed upon measurement. Mathematically, the uniform superposition state $|\psi_N\rangle$ for an n -qubit system can be expressed as:

$$|\psi_N\rangle = \frac{1}{\sqrt{N}} \sum_{k=0}^{N-1} |k\rangle$$

where,

$N = 2^n$, n denotes the number of qubits in the system,

$|k\rangle$ represents the computational basis states ranging from $|0\rangle$ to $|N-1\rangle$,

The factor $1/\sqrt{N}$ ensures that the state is normalized, meaning the total probability across all possible states sums to 1, as required by quantum mechanics. In this state, each possible basis state $|k\rangle$ has an equal amplitude of $1/\sqrt{N}$, giving it an equal probability $1/N$ of being observed. This normalization is crucial for maintaining the proper interpretation of probabilities in the system.

In Figure 1, a simple quantum circuit consisting of two Hadamard gates is shown. The action of this circuit on the input quantum state $|00\rangle$ results in the quantum superposition state.

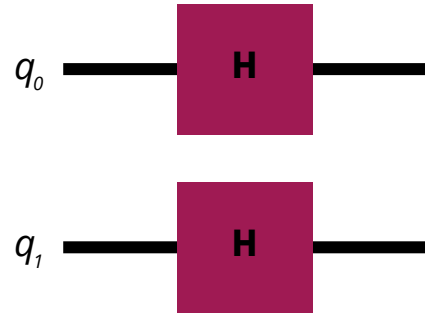

Figure 1: Quantum Circuit Consisting of Two Hadamard Gates

On carrying out measurement, each of the computational basis states is equally likely to be observed.

$$|\psi_4\rangle = \frac{1}{2} \sum_{i=0}^3 |i\rangle = \frac{1}{2} (|00\rangle + |01\rangle + |10\rangle + |11\rangle)$$

The same can be seen in Figure 2 through the probability distribution plot and in the Q-sphere plot in Figure 3.

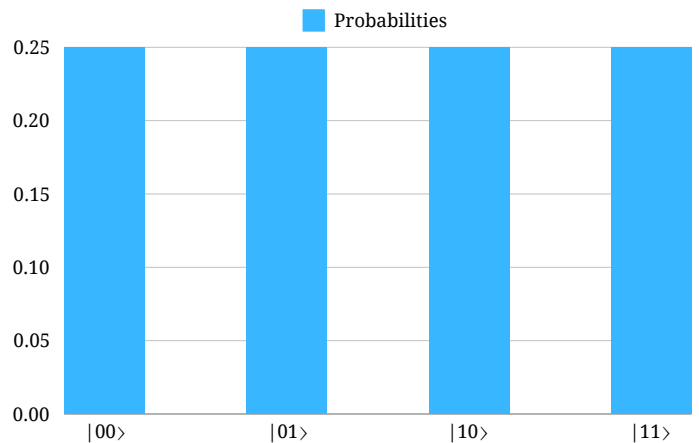

Figure 2: Probability Distribution Plot

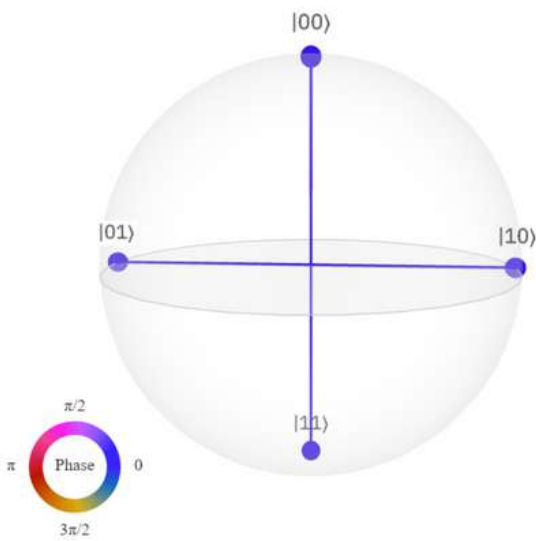

Figure 3: Q-sphere Plot

What are some challenges in creating these states?

Efficient creation of generalized uniform superposition states, where the number of states in superposition is not a power of 2 (e.g., 1,000 or 2 million), has long been a challenge until recently. Previous methods for constructing a superposition of M states, when M is not a power of 2, required $O(M)$ elementary quantum gates (or an equivalent number of CNOT gates, which we will refer to as quantum gates henceforth), making the process resource-intensive. In contrast, when M is a power of 2 (e.g., 1,024 or 2^{20}), the same task can be completed with a gate complexity of only $O(\log_2(M))$.

For instance, for $M = 1,000$, previous methods required approximately 1,000 quantum gates, whereas creating a superposition with $M = 1,024$ required just 10 quantum gates. For $M = 2,000,000$, previous methods needed around 2 million quantum gates, while a superposition with $M = 2^{20} = 1,048,576$ could be achieved with only 20 quantum gates. Similarly, for $M = 4,000,000$, around 4 million quantum gates were required using earlier methods, while a superposition with $M = 2^{21} = 2,097,152$ could be created with only 21 quantum gates. This stark contrast underscores the inherent

inefficiency of previous approaches for the general case when M is not a power of 2.

A New Algorithm - A Breakthrough

A significant breakthrough has been achieved recently [1], with the development of a new algorithm for the efficient creation of generalized uniform superposition states. It was demonstrated that for cases where M is not a power of 2, generalized uniform superposition states can be prepared using only $O(\log_2(M))$ qubits and $O(\log_2(M))$ quantum gates through a deterministic approach (remarkably, without the need for ancilla qubits). In terms of resource utilization (quantum gate complexity) and speed (quantum circuit depth), this represents an exponential improvement over previously known methods for creating generalized uniform superposition states. For example, when the number of states in superposition takes the form $M = 2^r + 2$, the new algorithm requires just $r + 2$ quantum gates. To put this into perspective, a state preparation that previously required over 2 million quantum gates can now be accomplished with just 23, and a task that would have required over 4 million gates now needs only 24.

Quantum circuits to obtain the uniform superposition states.

$$|\Psi_M\rangle = \frac{1}{\sqrt{M}} \sum_{k=0}^{M-1} |k\rangle$$

For $M = 15$, is shown in Figure 4.

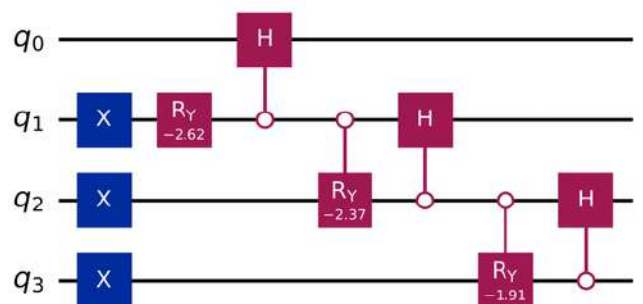

Figure 4: Quantum Circuits to Obtain the Uniform Superposition States (M=15)

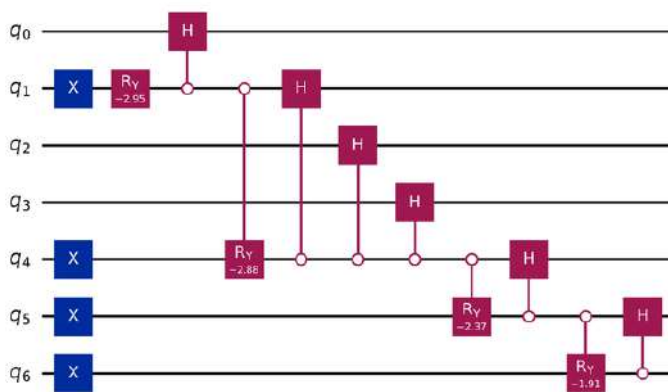

Figure 5: Quantum Circuits to Obtain the Uniform Superposition States (M=115)

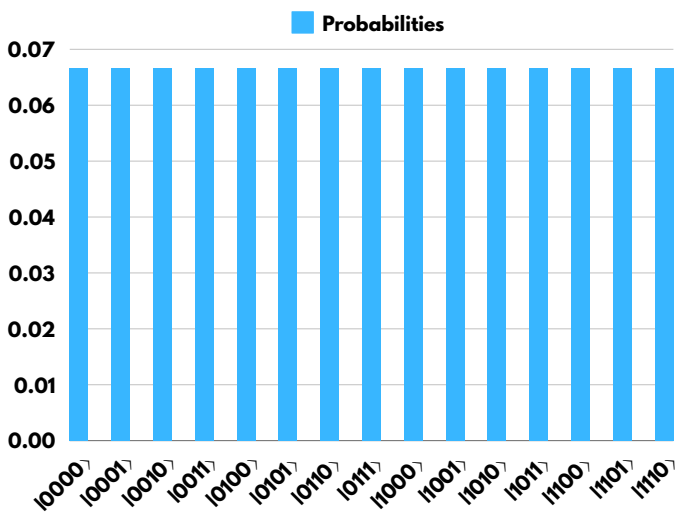

Figure 6: Probability Distribution Corresponding to the Quantum Circuit Shown in Figure 4

Integration of this Algorithm into Quantum Platforms of IBM and Google as a New Quantum Gate

The quantum computing platforms developed by IBM (Qiskit) and Google (Cirq) have integrated this algorithm as a dedicated gate. For instance, Google’s quantum computing framework Cirq has introduced the UniformSuperpositionGate [2], allowing developers to easily incorporate uniform superposition states into their quantum circuits. Similarly, IBM’s Qiskit has made this functionality accessible to quantum programmers as a new gate UniformSuperpositionGate [3]. Given the significance of creating uniform quantum superposition states in quantum computing, it is expected that the UniformSuperpositionGate will become a part of many interesting quantum algorithms and applications.

References

- [1] Alok Shukla and Prakash Vedula. An efficient quantum algorithm for preparation of uniform quantum superposition states. Quantum Inf Process, 23(2):38, 2024.
- [2] Google Quantum AI (cirq) Uniformsuperpositiongate documentation
URL: <https://quantumai.google/reference/python/cirq/UniformSuperpositionGate>
- [3] IBM Qiskit Community Qiskit Release Notes, Version 1.2.0
URL: <https://docs.quantum.ibm.com/api/qiskit/release-notes/1.2#new-features>

Dr. Alok Shukla



Dr. Alok Shukla is a faculty member in the Mathematical and Physical Sciences division at Ahmedabad University. Before academia, he worked as a Software Engineer at TCS and IBM, and at HAL, where he contributed to the Avionics Systems of the Mig-27 fighter aircraft and the ALH Dhruv helicopter. He holds a Ph.D. in mathematics from the University of Oklahoma, USA, and served as a postdoctoral fellow at the University of Manitoba, Canada, before joining Ahmedabad University. He has expertise in quantum algorithms and their applications. His notable contributions include the development of efficient algorithms for preparing uniform quantum superposition states, achieving exponential improvements over existing methods. He has also introduced innovative approaches for trajectory optimization, digital image processing, signal filtering, and solving nonlinear differential equations, offering quantum or hybrid classical-quantum solutions with reduced computational complexity and enhanced efficiency.

High-tech Research to Economy – Quantum Entrepreneurship the way forward

**Mr. Subodh Vashist, RRI Bangalore. Founder nexAtom.
Prof. Sadiq Rangwala, RRI Bangalore. Co-founder nexAtom**

Quantum technology is seen as the next big thing in the fields of Computing, Sensing, Information and an ever increasing palate of use cases. The technology has potential of a paradigm shift in many domains as it generally harnesses the unique and classically non-intuitive properties of quantum mechanics. There have been similar times in the independent history of our nation, where indigenous technology was crucial for our nation. As examples, Space, Nuclear, Defense, Heavy Industries and Manufacturing, Energy and other technologies have a strong national base and were often technologically supported by multiple foreign countries, with a very prominent contribution by the erstwhile Soviet Union. However, one sector that India failed to capitalize on is in semiconductor technologies, and as a consequence in the past 50 years, the class of products that have relied on semiconductors has not been an important contributor to our manufacturing base and economic growth. This has handicapped indigenous hi-tech manufacturing up until the present day. Post Economic Liberalization in 1991, a key economic driver was in the Service Sector (IT), which was highly reliant on imported hardware with few local technical solutions/platforms.

The reason for the short overview of high-tech manufacturing in India is that, if we want to be self sufficient in high-tech Manufacturing sector, whether Quantum or Non-Quantum we have to work on research to economy model, i.e.

building the ecosystem and infrastructure for the various technologies of manufacturing sector via research to economy. In more scientifically advanced economies, this is the most successful route to the tech industry. Nexatom is one such attempt in the field of precision lasers, detectors, lasers-based instruments, as various enabling technologies solutions for Quantum and non-Quantum high-tech Industry.



Prototype



Market Entry unit v1 – 3D Model



Market Entry unit v1 - Actual

Figure 1: External Cavity Diode Lasers (ECDL)

First precision tunable laser prototypes of nexAtom were validated even before the company was established. As we planned to build our own lasers for our Quantum Interactions experiments in QuaInt Lab at RRI. These particular precision tunable lasers are semiconductor diode based lasers called External Cavity Diode Lasers (ECDL), these lasers are crucial for building ion or neutral atoms based Quantum Computing, Quantum memories, Quantum Sensing of microwaves, fields, inertial sensors etc. Apart from Quantum applications these same lasers are required by manufacturing industries for multiple use cases.

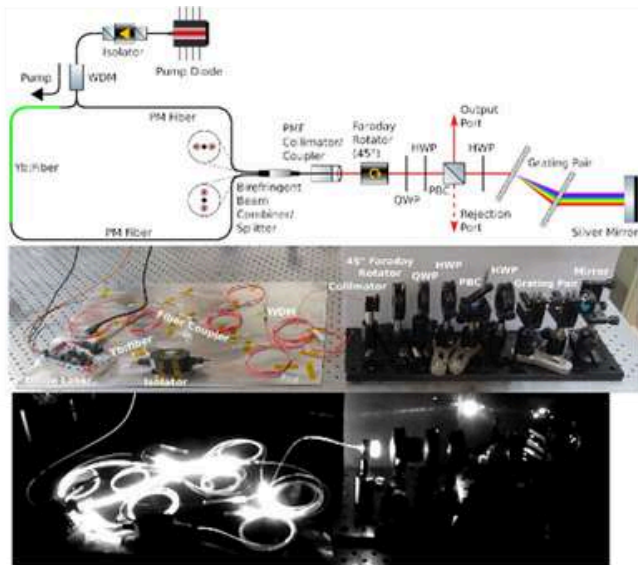

Figure 2: All-PM fiber based ultra-fast lasers

Apart from the ECDLs, which are under patent filing and for which we procured commercialization license from RRI, recently we have started validating All-PM fiber based ultra-fast lasers for Quantum and Defense Applications. These are very portable and stable femtosecond pulse lasers, whose train of extremely short pulses when impinged on micro-structured fibers with particular boundary condition, called Photonic Crystal Fibers (PCF) produces a very broadband light source in the form of comb lines. This broadband output can be used for various high-

tech precision and calibration broadband source for Quantum applications (Frequency Comb), Astronomy etc.



Figure 3: Time Tagger



Figure 4: High Speed DAQ

Similarly, we have various Field Programmable Gate Array (FPGA) based instruments without lasers, for example picosecond time taggers, which can measure multi-channel single photon hits with picosecond precision. We also have high speed FPGA based solution for control and monitoring of Quantum devices and Instrumentation for various requirements. In addition, we are working on Single Photon Avalanche Detector (SPAD) modules, Optical Phase Locked Loop (OPLL) modules, Wavemeters etc. Apart from the above-mentioned products we are also involved with various Institutes and Organizations to collaborate on very exciting and customized projects.

PORTFOLIO



Figure 5: Products with their current Technology Readiness Levels (TRLs) and market size (USD)

Mr. Subodh Vashist



Mr. Subodh Vashist is an engineer-turned-physicist and a PhD student specializing in experimental Atomic, Molecular, and Optical (AMO) physics at the Raman Research Institute (RRI) in Bengaluru. With a strong engineering background, he has been at the forefront of developing advanced embedded systems for turn-key laser controls. As the founder of nexAtom Research and Instruments, a spin-off from RRI, Mr. Vashist is dedicated to facilitating the scientific community in India through innovative solutions. His current research focuses on building state-of-the-art quantum systems from the ground up, with applications in areas such as ion-trap quantum computing.

Prof. Sadiq Rangwala



Prof. Sadiq Rangwala is an experimental physicist specializing in Atomic, Molecular, and Optical physics. He is currently a professor at the Raman Research Institute (RRI), Bangalore, working with ultracold atoms and ions, using precision laser systems and quantum optics techniques to study their interactions. Cold molecules and molecular ions are created from these atoms by forging bonds between them. He has received the Shanti Swarup Bhatnagar Award for his outstanding work on collisionally cooled ions with trapped atoms, leading to new discoveries in ultracold ion-atom physics. He also received the IPA P.K. Iyengar Award for Experimental Physics and is a Fellow of the Indian Academy of Sciences, Bangalore.

Quantum Currents

News and Updates from the
Quantum Universe



“Had a fruitful roundtable with tech CEOs in New York, discussing aspects relating to technology, innovation and more. Also highlighted the strides made by India in this field. I am glad to see immense optimism towards India.”

**- Shri Narendra Modi
Hon'ble Prime Minister of India**

Shaping the Future: PM Modi's Call for U.S. Partnerships in Quantum Innovation and Emerging Tech



Photo: X/Narendra Modi

During his recent U.S. visit, Hon'ble Prime Minister Shri Narendra Modi urged American tech leaders to strengthen their collaboration with India, particularly in the field of quantum computing. Addressing top executives from companies like Google, Adobe, and NVIDIA at a roundtable organized by the Massachusetts Institute of Technology (MIT), Modi highlighted India's ambition to become a global hub for emerging technologies such as quantum computing, AI, and semiconductors.

Quantum computing, which leverages the principles of quantum mechanics to perform calculations far beyond the capabilities of classical computers, was a major focus of Modi's address. He emphasized that India is making significant strides in this transformative field, which has the potential to revolutionize industries from cryptography to drug discovery. Modi invited U.S. companies to co-develop and co-produce quantum solutions in India, leveraging the country's rapidly expanding technological and research ecosystem.

The Prime Minister also pointed out that technology collaborations like the Initiative on Critical and Emerging Technologies (ICET) are central to the India-U.S. Comprehensive Global Strategic Partnership. ICET aims to deepen ties in critical areas such as quantum computing, AI, and semiconductor technologies. Modi's call to action reflects a broader vision to position India not just as an emerging market but as a leading player in next-generation technologies.

In addition to quantum computing, Modi highlighted India's advancements in AI and semiconductor manufacturing. He reiterated the country's commitment to becoming a global semiconductor hub, which is crucial for the development of advanced computing technologies. The Prime Minister also emphasized India's policy on promoting AI for all, with a strong focus on ethical and responsible use.

The CEOs at the meeting expressed optimism about India's growing role as a global technology hub, driven by its innovation friendly policies



Photos: Instagram/bjp4india

and a rapidly expanding market. Many showed a keen interest in investing in Indian startups and collaborating on innovative projects, particularly in areas like quantum research and AI.

Prime Minister Modi's pitch aligns with India's broader economic goals. Currently the fifth-largest economy in the world, India is on track to become the third-largest during the Prime Minister's current term. He highlighted

that by working with India, global companies could contribute to and benefit from this growth trajectory.

The roundtable was part of a larger strategy to attract global investment and foster innovation in India's tech sector. Modi's message was clear: India is not only open for business but is poised to lead in pioneering technologies that will shape the future.

Source: MEA

Principal Scientific Adviser to Govt. of India Prof. A.K. Sood Launches Thematic Hubs and Technical Groups under National Quantum Mission

In a major development for India's National Quantum Mission (NQM), the selection of premier institutions to establish Thematic Hubs (T-Hubs) was announced by Dr. Jitendra Singh, Union Minister of State for Science and Technology, during a virtual event in New Delhi. These T-Hubs will drive cutting-edge quantum research, positioning India as a global leader in quantum technologies.

The four T-Hubs, established at IISc Bengaluru, IIT Madras (in collaboration with CDOT New Delhi), IIT Bombay, and IIT Delhi, will focus on key quantum areas: Quantum Computing, Communication, Sensing & Metrology, and Materials & Devices. These institutions, selected through a competitive process, will work in collaboration with 17 technical groups across the country.

Dr. Singh highlighted the multidisciplinary approach of the T-Hubs, bringing together experts from diverse fields like physics, maths,

computer science, and engineering to push quantum innovation. "The hubs will lead India's efforts in quantum technologies," he remarked.

Following the NQM's Call for Proposals in January 2024, 17 projects were selected from 384 submissions, involving 152 researchers from 43 institutions across India. This collective effort will advance quantum research while also fostering collaboration between academia, industry, startups, and government entities.

Each T-Hub will operate under the Hub-Spoke-Spike model, facilitating a network of research collaborations and resource-sharing. The NQM has also set guidelines for supporting startups and promoting national and international partnerships to ensure India remains at the forefront of quantum advancements.

The mission's long-term goal is to establish India as a global leader in quantum technologies, driving sustained growth and innovation through the development of these hubs.

Institutes Involved in the T-Hubs:

Thematic Hub for Quantum Computing: Indian Institute of Science (IISc), Bengaluru

Institutions Involved: IIT Delhi, IIT Kanpur, IIT Roorkee, IIT Bombay, IIT Madras, IIT Ropar, IIT Guwahati, IIT Patna, BITS Hyderabad, IMSc Chennai, IIIT Noida, SETS Chennai, CDAC Bengaluru, IIT Indore, IISER Thiruvananthapuram, IISER Pune, RRI Bengaluru, NISER Bhubaneswar, TIFR Mumbai, TIFR Hyderabad and JNCASR Bengaluru

Thematic Hub for Quantum Communication: Indian Institute of Technology (IIT), Madras, and Centre for Development of Telematics (C-DOT), New Delhi

Institutions Involved: ISRO Ahmedabad, ISRO Satellite Centre, IIT Delhi, IIT Kanpur, IIT Kharagpur, IIT Bhilai, IIT Roorkee, IIT Jammu, IIT Tirupati, IIT Patna, IIT Indore, IIT Hyderabad, IISc Bengaluru, IISER Bhopal, IISER Mohali, RRI Bengaluru, HRI Prayagraj, IIST DOS Thiruvananthapuram, CDAC Bengaluru, C-DAC Thiruvananthapuram and SETS Chennai

Thematic Hub for Quantum Sensing and Metrology: Indian Institute of Technology (IIT), Bombay

Institutions Involved: IISc Bengaluru, IIT Madras, IIT Delhi, IIT Kanpur, IIT Gandhinagar, IISER Bhopal, IIT Ropar, TCG CREST Chennai, TIFR Bombay, TIFR Hyderabad, HRI Prayagraj, IACS Kolkata, BITS Goa, University of Hyderabad and SN Bose NCBS

Thematic Hub for Quantum Materials and Devices: Indian Institute of Technology (IIT), Delhi

Institutions Involved: IIT Bombay, IIT Madras, IIT Kanpur, IIT Roorkee, IIT Kharagpur, IIT Bhubaneswar, SSPL- DRDO Delhi, IACS Kolkata and IISER Pune

Source: PIB

India Achieves Major Quantum Computing Milestone with Successful 6-Qubit Processor Test



Photo: TIFR

In a groundbreaking achievement for India's quantum technology aspirations, scientists collaborating from the Defence Research and Development Organisation's (DRDO) Young Scientists Laboratory for Quantum Technologies (DYSL-QT) and Tata Institute of Fundamental Research (TIFR) have successfully completed the end-to-end testing of a 6-qubit quantum processor. This significant milestone demonstrates India's progress in quantum computing and positions the nation on the global quantum technology stage.

The successful test, conducted at TIFR's Colaba campus in Mumbai, involved the execution of a quantum circuit on a superconducting quantum processor, followed by the computation of results and their update via a cloud-based interface. The apex committee overseeing DYSL-QT witnessed the entire process, marking a critical step forward in India's quantum research.

The project is the result of a three-way collaboration between DYSL-QT, TIFR, and Tata Consultancy Services (TCS). DYSL-QT scientists

developed the control and measurement related apparatus using a combination of commercially available electronics and custom-programmed development boards. Meanwhile, the qubits fundamental units of quantum information were designed and fabricated at TIFR using a novel ring-resonator architecture, an innovative design pioneered by TIFR researchers. The cloud-based interface that connects to the quantum hardware was developed by TCS, highlighting the collaboration between scientific research and industry expertise.

With this breakthrough, the research team is now focused on optimizing the system's performance to ensure its operational readiness. The goal is to provide wider access to this quantum processor for educational institutions, researchers, and engineers. The system is also intended to serve as a testbed for analyzing superconducting quantum devices, opening doors to advanced research and development in quantum technologies. As the team refines the system, they advance quantum research in India and enable significant breakthroughs.

Looking ahead, the next phase of development aims to scale up the number of qubits in the processor. This will involve tackling the technological challenges, development timelines, and financial resources required to build larger and more powerful quantum systems. The team will assess the feasibility of scaling up from a theoretical, engineering, and business standpoint, considering the commercialization of quantum computers in the future.

This quantum computing advancement marks a pivotal moment in India's technological landscape. As the nation continues to develop expertise in quantum technologies, the successful testing of the 6-qubit quantum processor showcases India's growing influence in this cutting-edge field. The project exemplifies the power of collaboration between government research bodies, academic institutions, and industry leaders in driving innovation.

Source: PIB



Photo: DRDO

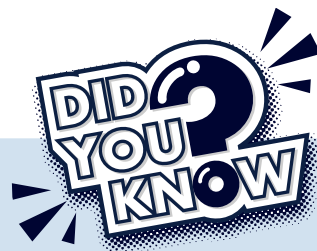

Teleportation: The instant transfer of objects or people from one location to another has been a fascinating concept in science fiction for decades. While physical teleportation remains impossible, science has made strides in a different kind of teleportation.

Quantum Teleportation: This process, first demonstrated in 1997, allows the quantum state of a particle to be transferred to another particle at a distant location, without physically moving the particle itself! It relies on the principles of quantum entanglement and the transmission of classical information. Though it's not the teleportation of Star Trek, it could revolutionize secure communication and quantum computing in the future.

Indian Researchers Achieve Quantum Leap in Cybersecurity with Unpredictable Random Number Generation



Pic Courtesy: Freepik.com

In a groundbreaking advancement for cybersecurity, Indian researchers have developed a cutting-edge method to generate truly unpredictable random numbers, a crucial innovation for enhancing encryption in quantum communications. This breakthrough, achieved by the Quantum Information and Computing (QuIC) lab at the Raman Research Institute (RRI) in Bengaluru, has the potential to transform how sensitive data is protected in the digital age.

Quantum encryption relies on the inherent unpredictability of random numbers, which act as a key in securing communications. The randomness used prevents malicious actors from predicting or deciphering secure information. The team at RRI, an autonomous institute under India's Department of Science and Technology (DST), successfully demonstrated this capability through a photonic experiment that violated the Leggett Garg Inequalities (LGI), a key test for determining "quantumness" in a system. This experiment was conducted in a loophole-free manner, ensuring the reliability of the randomness generated.

Over the past few years, RRI researchers, in collaboration with scientists from the Indian Institute of Science (IISc), IISER Thiruvananthapuram, and the Bose Institute in Kolkata, have explored the use of this LGI violation to generate random numbers in a completely new domain. These random numbers are essential for applications such as cryptographic key generation, secure password creation, and digital signatures, which are all critical components of modern cybersecurity.

"Our experimental setup ensures a loophole-free violation of LGI, allowing us to generate randomness that cannot be compromised," said Professor Urbasi Sinha, faculty at RRI and lead author of the study, published in *Physical Review Letters*.

In today's world, where digital interactions are the norm, the need for strong passwords and robust security measures has never been greater. The method developed by the RRI team offers enhanced protection by generating truly random keys that can be used to encrypt highly

sensitive information, making it resistant to cyberattacks. The randomness produced by this new system is particularly resilient against attacks on the initial state, a common vulnerability in encryption schemes.

"The certified random numbers generated are critical because any predictability could compromise the entire security framework," Professor Sinha added. "This new method ensures data integrity, robust encryption, and trust in digital interactions."

Traditionally, quantum systems that generate random numbers rely on two-particle setups, which can be complex and prone to noise interference. However, the RRI team's breakthrough replaces this with a more efficient single-particle approach. By using temporal rather than spatial separation to measure correlations, the new setup simplifies the process while still producing high-quality randomness. This system generated over 900,000 random bits at an impressive rate of 4,000 bits per second,

making it ideal for applications that require rapid and reliable randomness.

Looking beyond its cybersecurity applications, this new technology has the potential to revolutionize other fields as well. With further engineering refinements, devices using this method could find widespread use in simulations, randomized control trials, and statistical studies in areas like economic surveys and drug design.

"This innovation could serve as a foundation for future technologies that rely on provable unpredictability as a key resource," said Professor Dipankar Home from the Bose Institute, a co-author of the study.

This breakthrough positions India at the forefront of quantum cybersecurity research, offering a robust, scalable solution for securing digital communications and paving the way for broader applications in data protection and beyond.

Source: DST

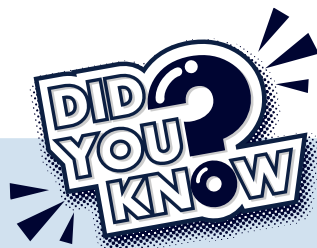

In the strange world of quantum mechanics, there's a rule against perfect copies! The **no-cloning theorem** states that it's impossible to create an exact replica of an unknown quantum state. This quirky rule means you can't "copy-paste" quantum information like you would with a file on your computer. It's a key reason why quantum data is so secure, any attempt to clone it would distort the original, revealing the presence of eavesdroppers. Quantum physics, it seems, has its own way of keeping secrets!

CDAC Advances Quantum Education with FDP at MAHE, Empowering Faculty in Emerging Technologies



Manipal Academy of Higher Education (MAHE) hosted a transformative Faculty Development Program (FDP) on quantum computing from September 9 to 13, 2024, led by the CDAC Bengaluru.

with the skills needed to integrate quantum technologies into their teaching.

Key speakers, including Dr. Asvija B., Dr. Naresh Raghava, Ms. Shikha Mehrotra, and Ms. Sahana Dermal shared their insights during the event. Participants were introduced to quantum algorithms and their applications, alongside hands-on sessions with QSim and Qniverse platforms, offering real-world practice in this emerging field.



This five-day program, part of CDAC Bengaluru's Quantum Outreach Program, brought together faculty from various disciplines like Computer Science, Mathematics, and Physics to provide them with an essential foundation in quantum computing. The initiative aimed to blend theory and practical knowledge, equipping educators

The sessions covered topics like qubit architectures, quantum error correction, and quantum communication, followed by hands-on work with the Quantum Network Simulator (QNS) to deepen understanding of quantum network protocols.

This FDP demonstrated CDAC's commitment to driving educational outreach in quantum computing, technology-focused education.

Source: C-DAC

AICTE FDP program on Quantum Artificial Intelligence & High Performance Computing for Industrial Digital Twins



A six-day Faculty Development Program (FDP) titled "Quantum Artificial Intelligence and High-Performance Computing for Industrial Digital Twins" commenced at Amrita Vishwa Vidyapeetham, Chennai Campus, on September 9, 2024, marking a significant milestone in educator training in advanced technologies.

The program focused on giving educators and researchers practical and theoretical knowledge in Quantum Artificial Intelligence (AI) and High-Performance Computing (HPC). Over the six days, expert mentors offered insights into the transformative potential of these technologies for both academia and industry.

By providing cutting-edge training, the FDP aimed at equipping participants with advanced knowledge, supporting their efforts to bring Quantum AI and HPC concepts to the classroom, while also addressing real-world industrial challenges.

Source: Amrita, Chennai



Funded by the All India Council for Technical Education (AICTE) under the ATAL scheme, the FDP was inaugurated by Mr. Henry Sukumar, Scientist 'F' and Associate Director at CDAC, Bangalore. His opening address highlighted the growing relevance of quantum technologies in industry, particularly Digital Twins, an advanced tool for simulating industrial processes.

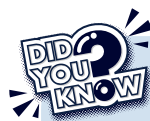

Hybrid HPC-QC systems combine the strengths of classical high-performance computing (HPC) with the potential of quantum computing (QC). While quantum computers excel at certain tasks, such as simulating quantum systems or solving optimization problems, they are still relatively limited in their capabilities. By integrating classical HPC systems, hybrid systems can leverage the best of both worlds, allowing for more efficient and powerful problem-solving.

List of selected publications in Quantum Technologies during July to September 2024

<p>Vacuum Beam Guide for Large Scale Quantum Networks.</p> <p><i>July 2024</i></p>	<p>Physical Review Letters, 133(2), 020801</p> <p><i>Huang, Y., Salces-Carcoba, F., Adhikari, R. X., Safavi-Naeini, A. H., & Jiang, L.</i></p>
<p>A quantum sensor for atomic-scale electric and magnetic fields.</p> <p><i>July 2024</i></p>	<p>Nature Nanotechnology, 1-6</p> <p><i>Esat, T., Borodin, D., Oh, J., Heinrich, A. J., Tautz, F. S., Bae, Y., & Temirov, R.</i></p>
<p>Hiding images in quantum correlations.</p> <p><i>August 2024</i></p>	<p>Physical Review Letters, 133(9), 093601</p> <p><i>Vernière, C., & Defienne, H.</i></p>
<p>Quantum repeater node with free-space coupled trapped ions.</p> <p><i>September 2024</i></p>	<p>Physical Review A, 110(3), 032603</p> <p><i>Bergerhoff, M., Elshehy, O., Kucera, S., Kreis, M., & Eschner, J.</i></p>
<p>Quantum Fourier transform using dynamic circuits.</p> <p><i>September 2024</i></p>	<p>Physical Review Letters, 133(15), 150602</p> <p><i>Bäumer, E., Tripathi, V., Seif, A., Lidar, D., & Wang, D. S.</i></p>



Keep in touch

Visit

www.quantumindia.net

or write to us to learn about all that is happening in Quantum World.

Email: quantum-outreach-blr@cdac.in



Subscribe to our newsletter

Content Management Team

Mr. Hari Babu, Dr. Asvija B, Mr. Henry Sukumar S,
Mr. Santhosh J, Ms. Shikha Mehrotra,
Dr. Naresh Raghava, Mr. Amit Saxena,
Mr. Aaditya Vitankar, Mr. Arunabh

C-DAC, No.1, Old Madras Road, Byappanahalli, Bangalore - 560038